

# Field Control Layer Device

# PF-PM11

## Modbus to BACnet MS/TP FCU Protocol Interface

### 【Description】

PF-PM11 is a network controller developed for the DF series FCU controller of AIRTEK. It can convert the commonly used DF series communication format to the BACnet MS/TP standard format to achieve the purpose of communication layer system integration. Group and individual monitoring, setting and control of fan groups, such as start-stop operation, temperature adjustment, wind speed switching, scheduled on/off and other setting and control, field temperature, system operation, wind speed operation, alarm abnormality and other status monitoring.

With DDC program control function, it can achieve various on-site requirements functions, such as various lock functions, billing and other functions. It can also achieve a software chain system host through DAC and other equipment. It can also be connected to operating displays, such as NFC, NFT, DSP, DST, 32 DF. controllers connected for on-site operation and monitoring.



### 【Features】

- Adopt international standard BACnet Advanced Application Controller (B-AAC) level communication protocol specification, compatible with BACnet system.
- A BACnet MS/TP RS-485 network communication port for connecting to the central monitoring system.
- With one MSnet network communication port, it can be connected to NFC, NFT, DSP, DST control panel.
- With one FCnet RS-485 serial communication port, each can be connected to 32 various DF. Controllers or DT4211M, DTC4211M and other equipment, automatically identify the connected equipment. With communication indicator, it shows the status of transmitting and receiving communication.
- With an RS-232 communication interface, the device parameters can be modified through the AD-Linker and the hyper terminal program.
- With clock function, when monitoring the connection, with the network time automatic synchronization function, can accept the network time correction of the central monitoring, so that the controller time in all systems is the same.
- The operating status and command parameters of 32 DF. microcomputer fan processors on the network can be converted into standard BACnet objects, and the operating parameters can be fully edited (Note: each DF. controller has up to 60 points (AI \*10 /AO\*10 /AV\*10 /BI\*10 /BO\*10 /BV\*10).
- Convertible monitoring points, such as fan start and stop, air-conditioning mode, wind speed, indoor and set temperature, timing and scheduled switch, fire alarm and temperature abnormal alarm, etc.
- With DDC control function, online editing, downloading control logic programs, and real-time debugging, with common HVAC calculation functions such as enthalpy, dew point temperature, PID control, and advanced mathematical operations such as logarithm, trigonometric function, and root sign Function functions, such as chain control calculations, group control functions, and group control functions can be achieved through program functions, and support the functions of reading and writing external device points.
- BACnet standard objects with a hardware clock, 2 calendars (Calendar), 20 schedules (Schedule), 4 notification classes (Notification Class), and 40 event enrollment. Schedule and alarm event registration support external object access function.
- With 100 BACnet analog software points (AV), digital software points (BV) and 10 digital output (BO) objects, the parameters are automatically stored in FRAM when the value/status changes, which can be used for billing or other energy management For calculation purposes, a total of 10 BO points from BO0 to 9 support the priority function.

### 【Specification】

Model	MS/TP port	FCnet port	MSnet port	DFC QTY	Calendar	Schedule	Notification	Event	AV Points
PF-PM11	1	1	1	32	2	20	1	10	100

**Power Supply** : 24VAC, 5VA.

**Microprocessor** : 32-bit high performance MCU, 128K SRAM, 32K FRAM and 1024K Flash memory.

**MS/TP Port** : RS-485 interface, communication speed 9,600/ 19,200/ 38,400/ 76,800 bps auto select, maximum length 1, 200 meters, having 2500Vrms optical coupling insulator and TVS ARRAY surge protection.

**FCnet Port** : MODBUS RTU RS-485 interface, communication speed 9,600bps, maximum length 1,200 meters, each port can connect up to 32 DFC controllers.

**MSnet Port** : MODBUS RTU RS-485 interface, maximum length 1,200 meters, connect to an operator display control panel.

**Realtime Clock** : Gold capacitor power redundancy, provide power failure the clock normal operation.

**Environment** : 0~50°C, 20~90%RH.

**Certification** : CE, RoHS.

## 【Installation】

- A solely transformer is required. Do not share power supply with another device.
- FCnet communication port can link to the actual number of the connection device characteristics, the amount of data and data formats. Normally, it will be 32 devices for each RS-485 network.
- MSnet can connect an NVC, NFC, DSP or DST group control panel. ( Note: When MSnet port connects to a NVC51V panel then FCnet unacceptable to connect a DT4211M or DTC4211M controller.)
- FCnet communication port connects to Slave devices in Master mode and only support AIRTEK DFC series not for other models or other brands.
- Put 120ohm end resistor on both sides of the network to prevent weak signal.

## 【Network Architecture】

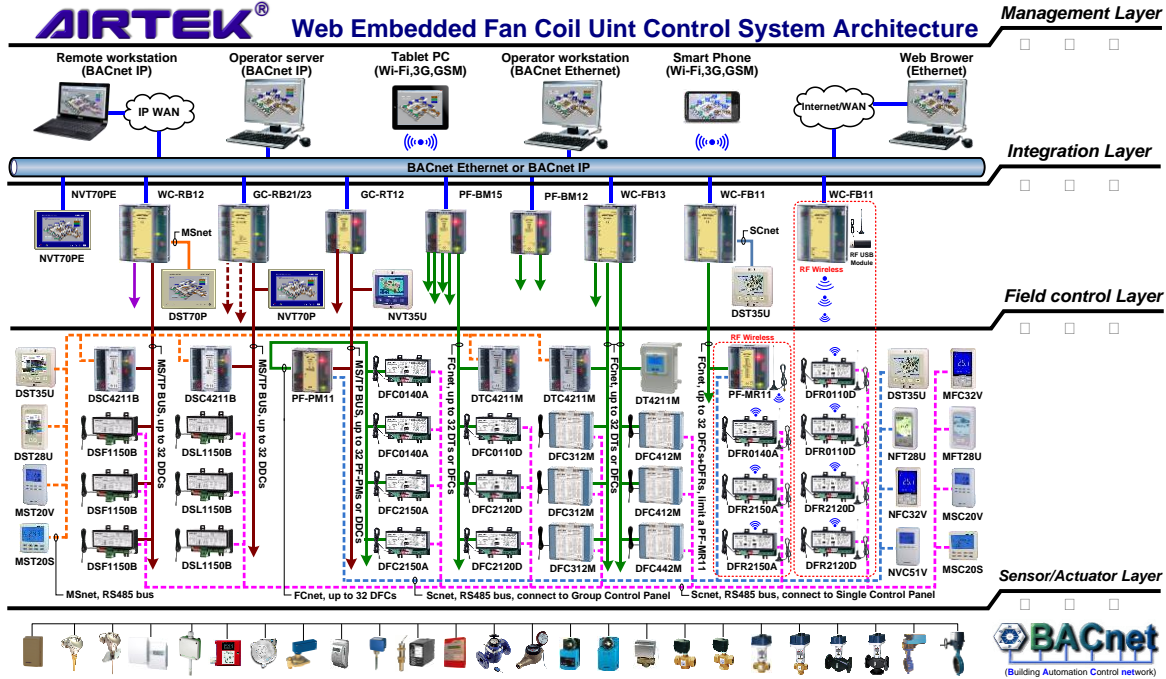

## 【Wiring Diagram】

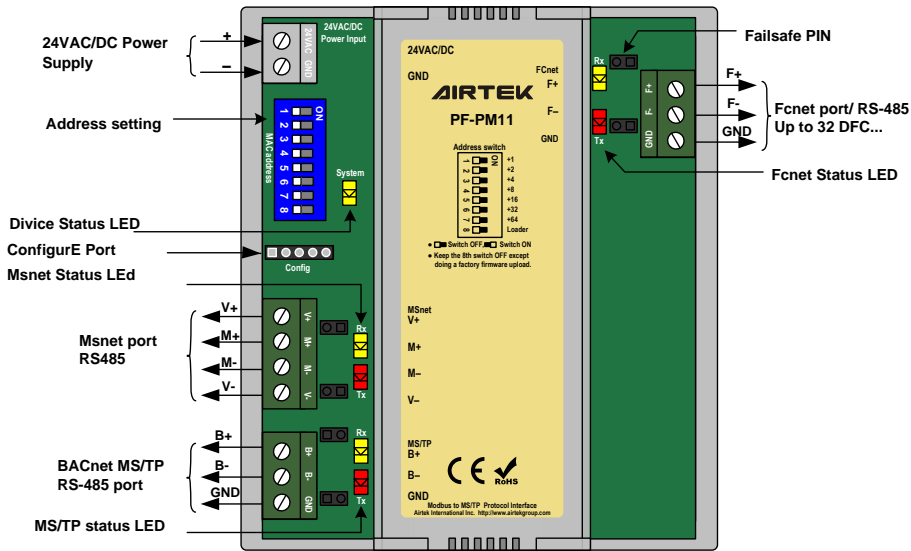

## 【Dimension】 Unit : mm

